

LANGO®

Solenoid Dosing Pump Instruction Manual

EH
Series



Carefully read and understand the manual before installation and operation.

Order confirmation

After unpacking, check the following points. Contact us or your nearest dealer if the delivery is imperfect.

a. Check if the delivery is as per order.

Check the nameplate to see if the discharge capacity, discharge pressure and voltage are as per order.

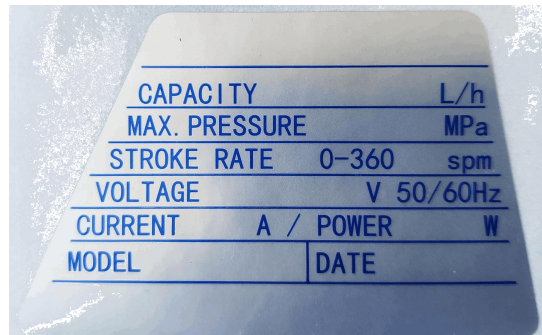

CAPACITY	L/h
MAX. PRESSURE	MPa
STROKE RATE	0-360 spm
VOLTAGE	V 50/60Hz
CURRENT	A / POWER W
MODEL	DATE

b. Check if accessories are complete.

- A check valve

* The attached check valve vary with pump models.

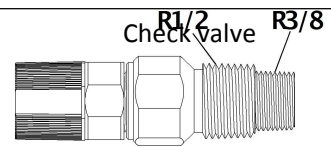

- A filter with foot valve

* The attached filter with foot valve vary with pump models.

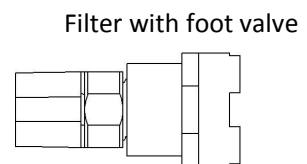

- A tube (3m)

($\varnothing 4 \times 9$ or $\varnothing 8 \times 13$ PVC braided tube)

c. Check if the delivery is damaged or deformed

Check for transit damage and loose bolts.

Part names



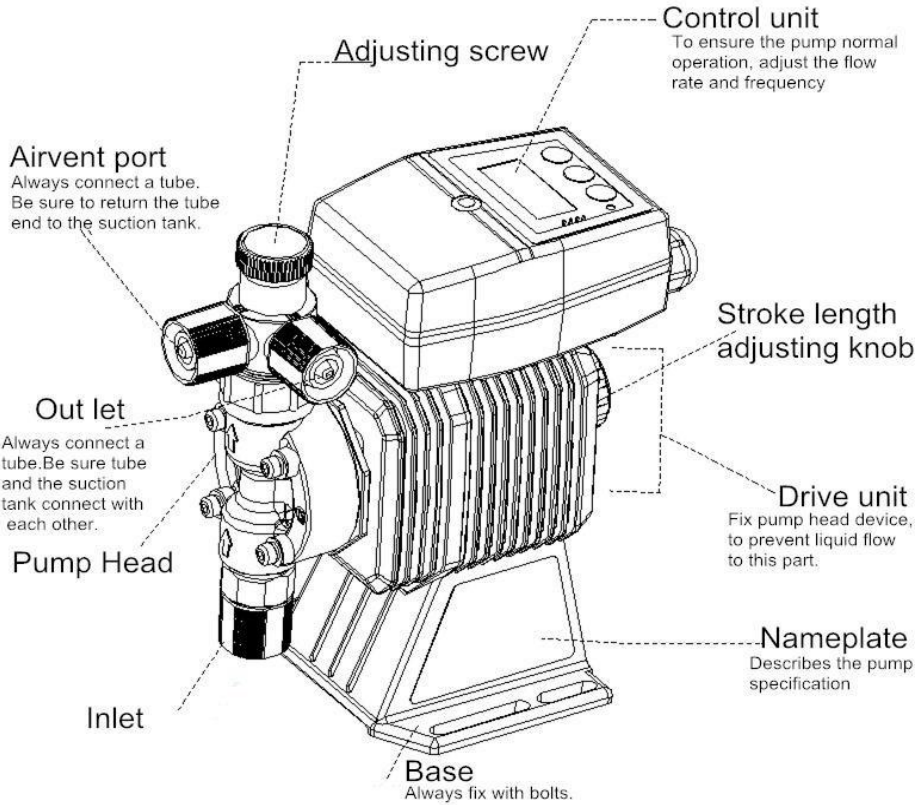



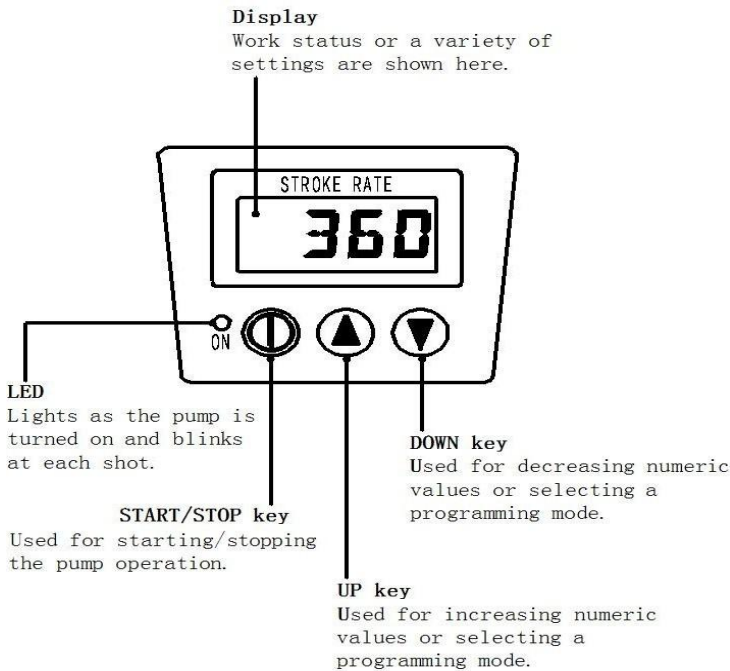





Pump



* The air vent port is not provided to the EH-□30•35 .

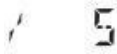

■ Basic displays & Pump states

	LED lights	LED blinks
	A wait state in manual mode The screen shows the manual operation spm.	Operation in manual mode. spm indication blinks. The screen shows manual operation spm.
	A wait state in EXT mode (E-EX), waiting for the external signal.	Operation in EXT mode (E-EX) receiving the external signal.
	A wait state in EXT mode (E-SP), waiting for the external signal. The screen shows ".0".	Operation in EXT mode (E-SP), receiving the external signal. The screen shows manual operation spm.
	The stop function is suspending the pump operation.	—
	The pump is stopped by the stop signal in the manual wait state.	—
	Anti-chattering programming T-5, T-10 and T50 are the approximate time (msec) to read the external pulse signal.	—
	Divide is selected in EXT mode.	—
	Multiply is selected in EXT mode.	—
	Divider is programmed in EXT mode. In this programming the pump makes one shot per 5-signal.	—
	Multiplier is programmed in EXT mode. In this programming the pump makes five shots per signal.	—
	STOP function is programmed.	—
	The input of the external signal is over the programmed upper limit spm in EXT mode. The pump runs at the programmed upper limit spm.	—
	Keypad is locked. In this state key operation is cancelled. First release the lock state before operation.	Keypad is locked. In this state key operation is canceled. First release the lock state before operation.

Identification codes

EH - B 10 VC W 1 C

1 2 3 4 5 6 7

1 . Series name

EH: Pulse Signal Model

2 . Drive unit code (Average power consumption)

B: 20W

C: 24W

3 . Diaphragm effective diameter

10/15/20/30/35

4 . Flow end materials

Code	Head	Ball	Seat	Cover	Gasket	Oring	Diaphragm
VC	PVC	Ceramic	FKM/EPDM	PVC	PTFE	FKM	Composite PTFE
VH	PVC	Ceramic	FKM/EPDM	PVC	PTFE	EPDM	
DF	PVDF	Ceramic	FKM	PVDF	PTFE	PTFE	
SU	SS316	SS316	SS316	SS316	PTFE	PTFE	

5 . Power-supply voltage

W: AC100-240V

6 . Tube connection bore code

1	ø4×6mm (PVC transparent tube 3m)
2	ø4×6mm (PE tube 3m)
3	ø4×9mm (PVC transparent braided tube 3m)
4	ø8×13mm (PVC transparent braided tube 3m)
5	ø4×6mm (PTFE transparent tube 3m)
6	ø8×10mm (PTFE transparent tube 3m)
7	1/4" female thread

7 . Plug type

A	Australia, New Zealand, Taiwan
B	British
C	China
E	Europe
U	United States
S	South Africa
X	No Plug

Installation

This section describes the installation of the pump, tubing and wiring. Read through this section before work.

! Observe the following points when installing the pump.

- Be sure to turn off power to stop the pump and related devices before work.
- Upon sensing abnormal condition or a dangerous sign, stop the work immediately. Remove problems before resuming work.
- Do not place dangerous or flammable goods near the pump for your safety.
- Risk of an electrical leak or shock. Do not use a damaged pump.

Pump mounting

Select an installation location and mount the pump.

Necessary tools

- Four M5 bolts (pump mounting)
- Adjustable wrench or spanner

1 Select a suitable place.

Always fix the pump on a flat floor free of vibration.

Flooded suction is recommended when handling a gaseous liquid such as sodium hypochlorite

2 Fix the pump by the M5 bolts.

Be sure to fix the pump at four points.

NOTE _____

Install the pump horizontally. If the pump is installed at a tilt, the flow may reduce.

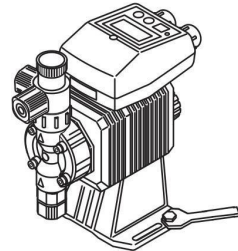

Pipework

Connect tubes to the pump and install a check valve.

Before operation

- Cut the tube ends flat.

Tube end (Side view)

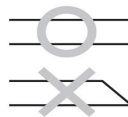

Necessary tools

- Adjustable wrench or spanner

Tube connection

- a. Pass a tube into the fitting nut and insert a tube end all the way seated on the fitting. Then hand tighten the fitting nut.
 - b. Retighten the fitting nut by turning it 180 degrees with an adjustable wrench or spanner.
- * The fitting nut is made by plastics and may be broken if it is tightened too much.

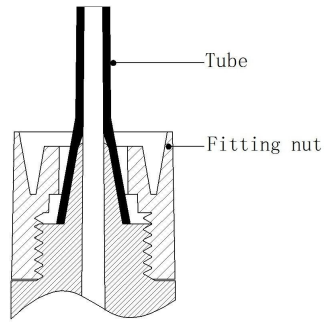

1

Connect tubes into the inlet and outlet.

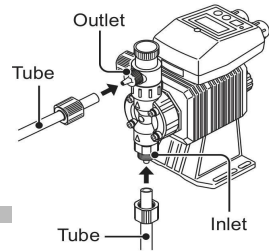

2

Connect an air bleed tube into the air vent port.

Place the tube end in the supply tank or another container.

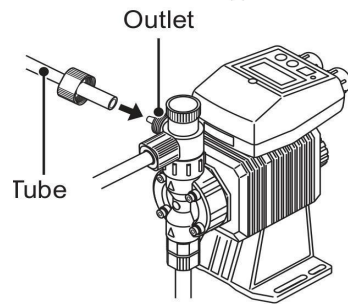

3

Direction of the air vent port.

The air vent port can rotate 90 degrees.

- A. Turn the lock nut anticlockwise.
- B. Adjust the direction of the air vent port.
- C. Turn the lock nut clockwise and fix it, holding the air vent body A.
- D. Further tighten the lock nut by turning it 90 degrees with an adjustable wrench or spanner.

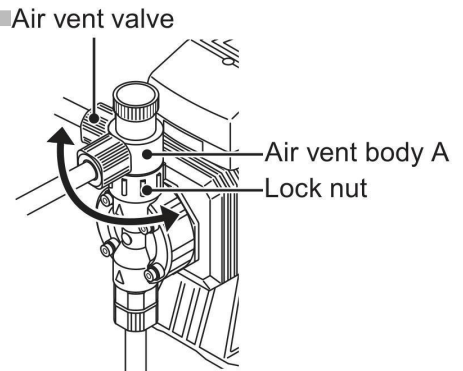

The air vent port is not provided to the EH-30•35 types. Install an air vent valve. See the right diagram. Optional air vent valves are available. See page 82 for detail.

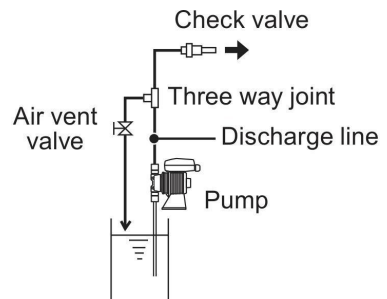

Check valve mounting

The EH series is equipped with a check valve for the prevention of back flow, siphon and overfeeding.

In the following cases be sure to install the check valve.

- The suction side liquid level is higher than the discharge side (See the diagram below). Or an injection point is below the suction side liquid level at atmospheric pressure.

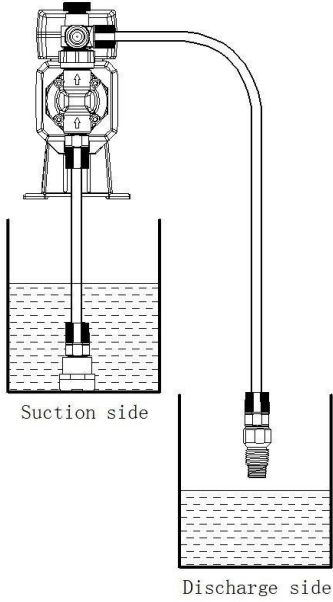

- Suction side pressure is higher than the discharge side pressure.

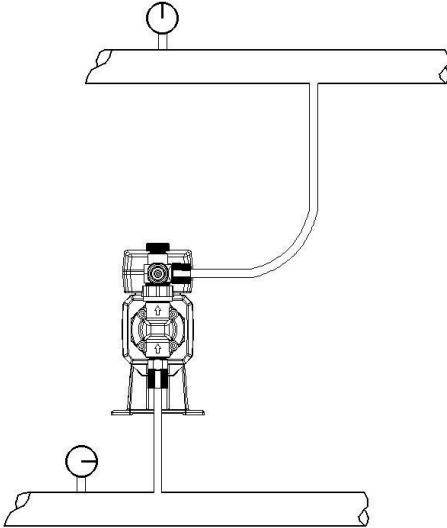

Wiring for the power source, earthing and external signal.

⚠ Observe the following points during wiring work.

- Electrical work shall be performed by a qualified operator. Always observe applicable codes or regulations.
- Observe the rated voltage range. Otherwise the electrical circuit on the control unit may break.
- Do not perform wiring work while the power is on. Otherwise, an electrical shock and short circuit may result, and consequently the pump may fail. Be sure to turn off power before wiring work.
- Be careful for the power not to be turned on during work.

Necessary tools

- Adjustable wrench or spanner
- Phillips screw driver
- Precision screw driver

Power supply/Earthing

Check that the main power is turned off.

Connect power cable via crimp contacts.

1

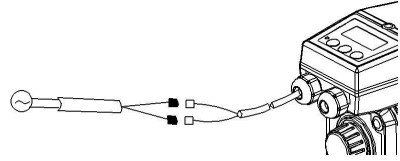

2

Earth the pump.

Be sure to earth the pump.

NOTE

- Do not share a power source with a high power equipment which may generate surge voltage. Otherwise electronic circuit may fail. The noise caused by the inverter also affects the electronic circuit.
- Power voltage should be charged at a sitting via a switch or a relay. Otherwise CPU may malfunction. See page 28 for the precautions for ON-OFF control by the relay.

When the power is applied at a sitting

When the power is applied gradually

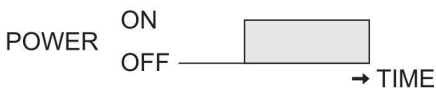

Precautions for ON-OFF control by the relay

The control unit is equipped with CPU. Always start/stop the pump by the STOP signal. Do not start/stop the pump by turning ON/OFF power because it may adversely affect CPU.

If there is no choice but to turn ON/OFF power, observe the following points.

- Do not turn ON/OFF the power more than six times per hour.
- When using a relay for ON-OFF operation, its contact capacity should be 5A or more. Contact point may fail if contact capacity is less than 5A.
- If the contact capacity of 5A is used for the EH, the maximum ON/OFF operation is about 150,000 times. Use the relay with the contact capacity of 10A or more when making ON-OFF operation over 150,000 times or sharing a power source with a large capacity equipment. Otherwise a contact may fail by surge voltage.
- Use non contact transistor relay as necessary (ex. OMRON G3F). See manufacturer's catalogues for detail.

Surge voltage

The electronic circuit in the control unit may fail due to surge voltage. Do not place the pump close to the high power equipment of 200V or more which may generate large surge voltage.

If the use near the high power equipment is inevitable, take any of the following measures.

- Install a surge absorption element (ex. a varistor with capacity of 2000A)

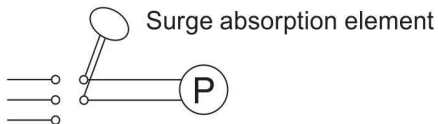

Recommended varistors

Panasonic ERZV14D431

KOA NVD14UCD430

See manufacturer's catalogues for detail.

- Install a noise cut transformer via power



Noise cut

External input cable

Points to be checked

- Check that the main power is turned off.
The pump is still charged right after turning off power. Wait for one minute before wiring.

Applicable cables

A cable diameter shall be 7.8mm.

Triplex cable: VCTF-3 1.25mm²

Duplex cable: UL, CSA SJT 18AWG/2

- * The use of a cable diameter other than 7.8mm results in improper connection and reduced seal performance.

NOTE

- Do not install the EXT/STOP signal wires in parallel with a power cable or combine them in a concentric cable (ex. 5 wires cable). Otherwise distractions is generated through the EXT/STOP signal wires due to induction effect and it results in malfunction or failure.

*Use either a no-voltage contact or an open collector for the external signal.

* Set pulse duration in 10-100ms and the number of pulses at or below 360 pulses per minute .

1

Remove the control unit.

- Remove the rubber cap, fixing screw and gasket from the top.
- Loosen the two tapping screws (A) located above the stroke length adjusting knob and detach the control unit.

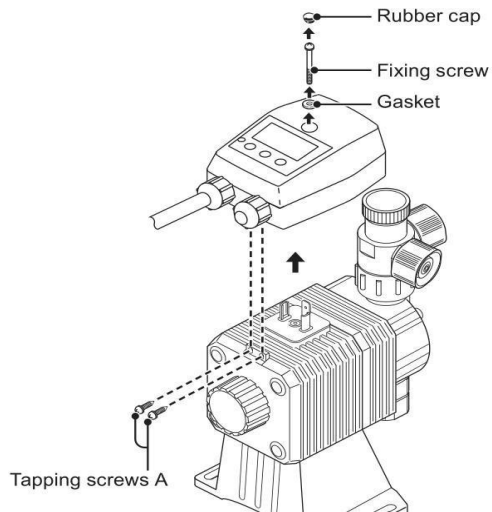

2

Remove four screws (B) from the bottom of the control unit to detach the controller cover.

- * The controller cover can not be totally removed because the screen on the controller cover and the PCB on the controller case are connected via cable.
- * The controller cover and the controller case are sealed by a case gasket. Do not forget to fit the case gasket when mounting the controller cover.

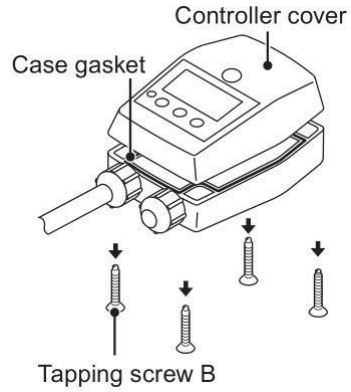

3

Remove a cord nut and a cap and pull out a cord gasket.

- * The cap is no longer used.

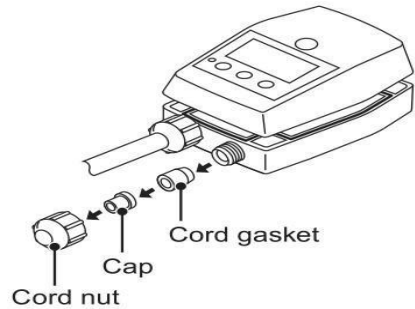

4

Pass the external signal cable into the control unit via the cord nut and the cord gasket.

- * Be careful not to oppositely orient the cord gasket.

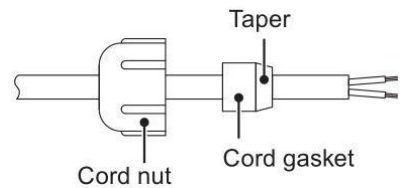

5 Connect an external signal cable.

- Detach the plug from the socket.
 - Use a precision screwdriver to connect the signal wires on the plug and then attach the plug to the socket.
 - Adjust the slackness of the external signal cable, pulling it out.
 - Securely hand tighten the cord nut.
- * The external signal cable is sealed by the cord gasket.

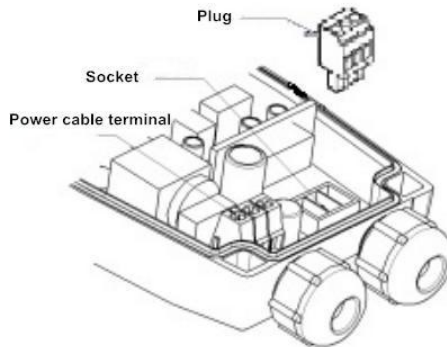

Wiring diagram

When a no-voltage contact is used

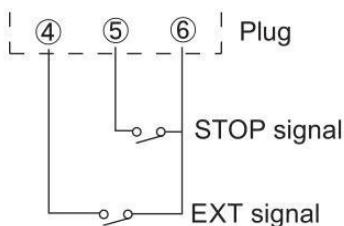

When an open collector signal is used

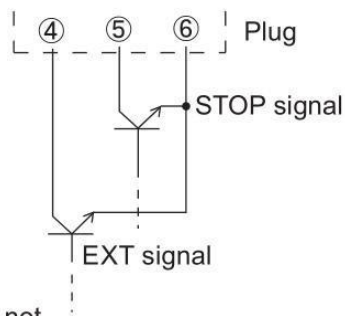

*The pump does not break but not run if wiring is done incorrectly.

6 Attach the controller in a reverse way of the item 1 and 2.

Tightening torque

Fixing screw (For mounting control unit)	0.39 N•m
Tapping screw A (For mounting control unit)	0.39 N•m
Tapping screw B (For mounting control cover)	0.8 N•m

NOTE

Always check that gaskets (a rubber cap, fixing screw gasket and a case gasket) are fitted. Otherwise, the liquid may enter the control unit and failure may result.

Points to bechecked

Before operation, check if...

- Liquid level in the supply tank is enough.
- Tubing is securely connected and is free from leakage and clogging.
- Discharge/suction valves are opened.
- Proper power voltage is applied to the pump.
- Electrical wiring is correct and is free from the risk of short circuit and electrical leakage.

Retightening of pump head fixing bolts

Important

The pump head fixing bolts may loosen when plastic parts creep due to temperature change in storage or in transit.

This can lead to leakage. Retighten the pump head fixing bolts before starting operation.

Always tighten the bolts diagonally. See below for the tightening torque at each model.

Tightening torque

Model identification code	Torque	Bolts
EH-B10/B15/B20,C15/C20	2.16 N•m	M4 Hex. socket head bolt
EH-B30	2.55 N•m	M4 Hex. socket head bolt
EH-C30	2.55 N•m	M4 Hex. socket head bolt
EH-C35	2.55 N•m	M4 Hex. socket head bolt

*Tighten fixing bolts once every three months.

■ Use of hexagon wrench instead of a torque wrench

Tighten the fixing bolts with the straight long part of a hexagon wrench (a) and further turn the bolts clockwise 90 degrees with the short part (b).

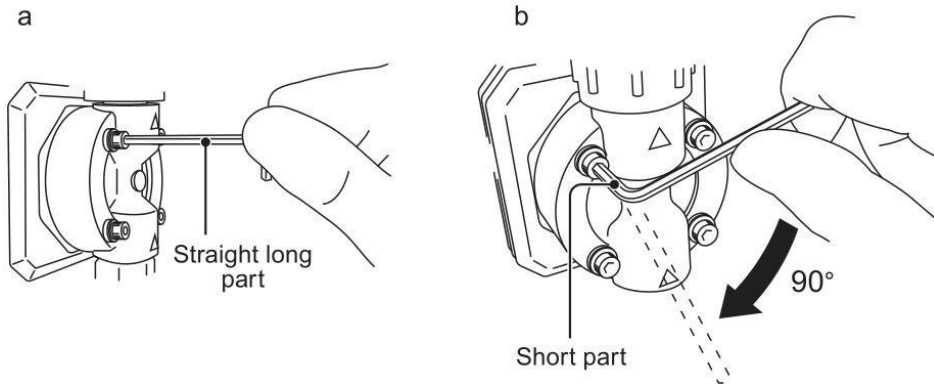

Degassing

The gas needs to be expelled from the pump and tubing by degassing. Normal operation can not be obtained with gas in the pump. Perform degassing in the following cases.

- When the pump starts to run for the first time
- When the flow rate is too low
- After liquid is replaced in the supply tank
- After a long period of stoppage
- After maintenance and inspection

NOTE

- Both gas and chemical come out together through air bleed tube. Place the end of the tube in the supply tank or another container.
- Some chemicals may cause skin trouble or damage component parts. When your hand or component parts get wet with chemical liquid, wipe off immediately.

■ EH- [B10/B15/B20/C15/C20] [VC]

Points to be checked

- An air bleed tube is connected to the pump.

Air bleed tube

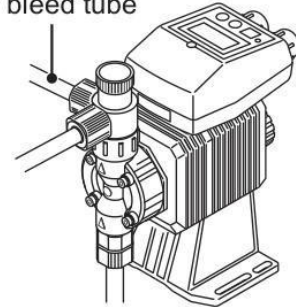

1. Turn on power.

The LED lights and a display related to the current mode appears on the screen.

- * The pump enters the wait state in the manual mode when turning on power with a default setting. The pump calls up the last screen at a shutoff if it was not in a default setting.

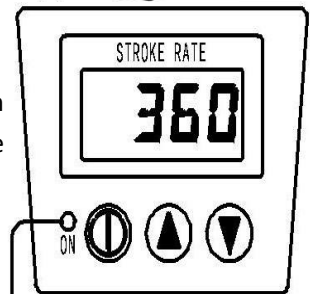

2. Program the stroke rate to 360spm.

- This programming is not necessary when the display already shows 360. Move to the next step.

3. Rotate the adjusting screw two revolutions anticlockwise to open the air vent port.

- * Do not rotate it three revolutions. Otherwise, liquid may come out from the air vent port.

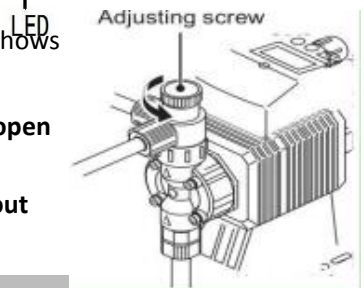

4 Push the start/stop key and run the pump for more than ten minutes.

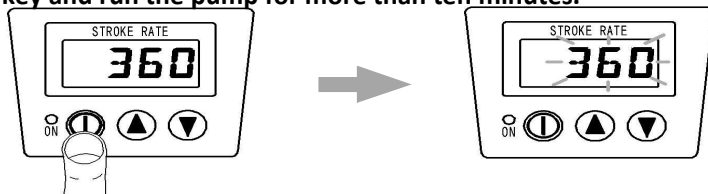

5. Push the start/stop key and stop the pump.

6. Rotate the adjusting screw clockwise to close the air vent port. Check liquid is discharged.

- * Degassing is required again if the pump does not discharge liquid.

7. Check connections for leakage.

8. Degassing has now been completed.

■ EH- [B30/C30/C35] [VC]

The air vent port is not provided to the EH-30/35 VC types.

Install an air vent valve on the discharge line for degassing. Follow the procedure below to conduct degassing if the air vent valve is not available.

1 Connect a discharge tube and place the tube end in the supply tank or another container.

- * Remove the check valve from the discharge tube if it is installed.
- * When resuming the pump operation after liquid replacement in the supply tank or after a long period of stoppage, the internal pressure may remain in the pump or tubing. Removing the check valve at this state, liquid may gush out. Wrap a waste cloth around the check valve connection for the prevention of gushing.

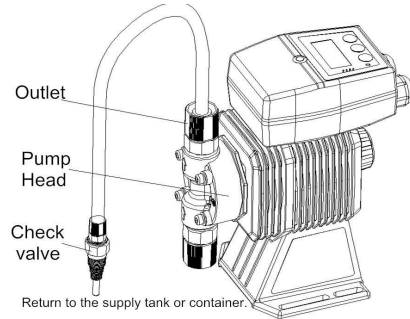

2 Turn on power.

The LED lights and a display related to the current mode appears on the screen.

- * The pump enters the wait state in the manual mode when turning on power with a default setting. The pump calls up the last screen at a shutoff if it was not in a default setting.

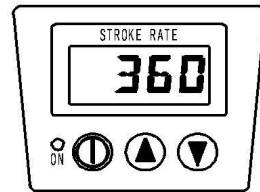

3 Program the stroke rate to 360spm.

- This programming is not necessary when the display already shows 360. Move to the next step.

4 Push the start/stop key and run the pump for more than ten minutes.

The LED and spm indication blink during operation.

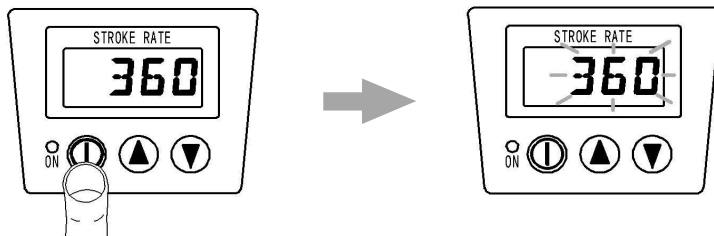

1 Turn on power and call up manual mode.

Enter manual mode to indicate spm on the screen.

- Push the EXT key when "EXT" or ".0"- ".360" is on the screen.
- When "STOP" or "-STOP" appears on the screen, see "STOP function cancellation" on page 60 and release the STOPfunction.

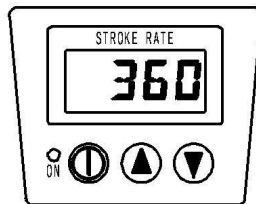

2 Use the UP or DOWN key to adjust stroke rate.

- spm increases/decreases as pushing the UP/DOWN keys.
- Press and hold either key for more than three seconds for quick change. Quick change stops at 1 or 360spm. 1 or 360spm skips to 360 or 1spm when the key is released and pushed again.

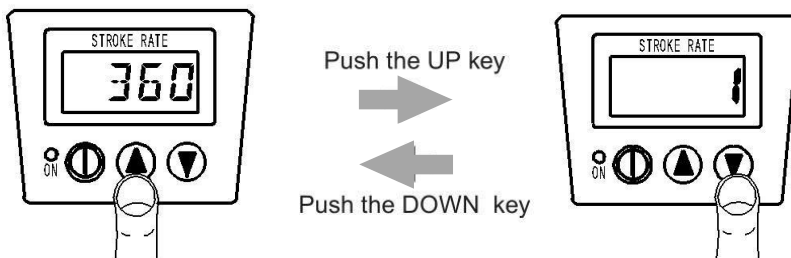

3 Push the start/stop key.

The LED and spm indication blink as the pump starts to run.

- They blink in sync with the pump operation.

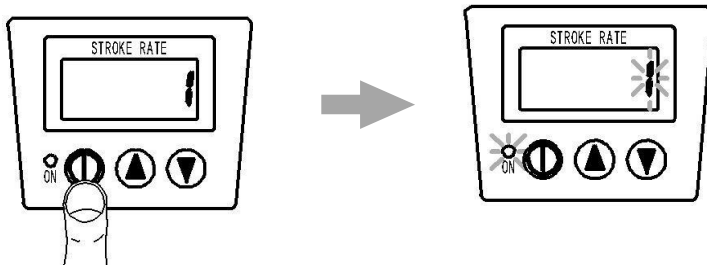

■ Stroke length adjustment

Stroke length can be adjusted when the moving distance of the plunger is changed by the stroke length adjusting knob.

The stroke length adjustment range is 50-100% for the B type, 40-100% for C type.

The relation between a flow rate* and stroke length is shown as below.

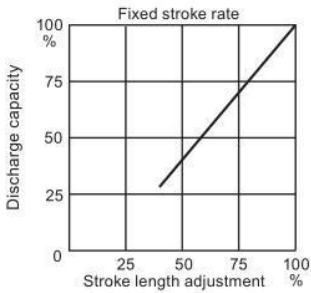

*The flow rate described on the nameplate is at 100%.

NOTE

Do not rotate the stroke length adjusting knob when the pump is not running.

1 Turn on power and push the start/stop key to run the pump.

The LED and spm indication blink during operation.

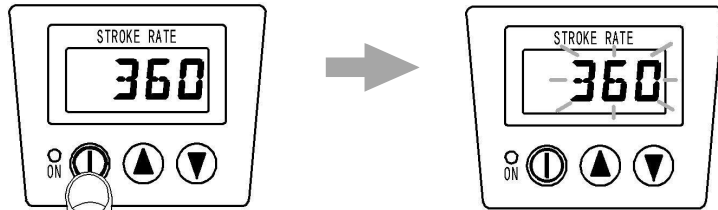

2 Rotate the stroke length adjusting knob and adjust a flow rate while the pump is running.

Stroke length adjusting knob

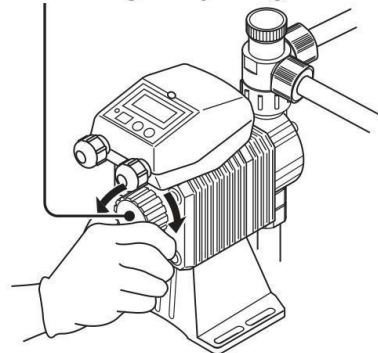

1 Turn on power.

The LED lights and a display related to the current mode appears on the screen.

* The pump enters the wait state in the manual mode when turning on power with a default setting. The pump calls up the last screen at a shutoff if it was not in a default setting.

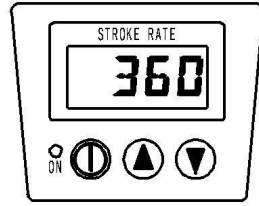

2 Enter manual mode.

Move to the next step when spm (1-360) is shown on the screen.

When "EXT" or ".0"-.360" is on the screen

Push the start/stop key once to enter the wait state in manual mode.

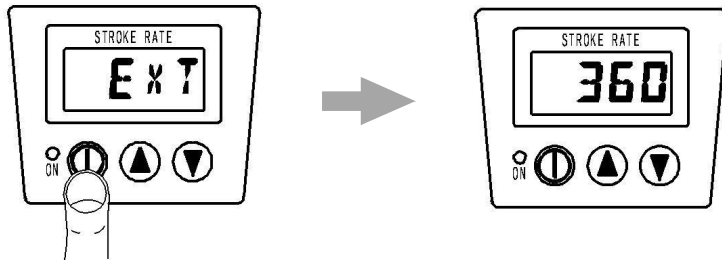

When "STOP" or "-STOP" is on the screen

See "STOP function cancellation" on page 60 and release the function.

3 Use the UP or DOWN key to adjust stroke rate.

- spm increases/decreases as pushing the UP/DOWN keys.
- Press and hold either key for more than three seconds for quick change. Quick change stops at 1 or 360spm. 1 or 360spm skips to 360 or 1spm when the key is released and pushed again.

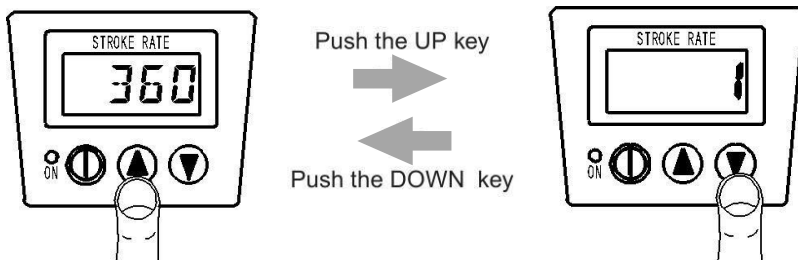

4 Push the start/stop key.

The LED and spm indication blink as the pump starts to run.

- They blink in sync with the pump operation.

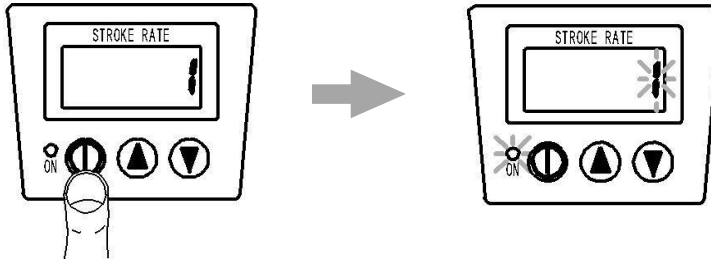

EXT operation

The pump operation is controlled by the external (pulse) signal.

■ EXT mode

Set the upper limit spm and enter EXT mode. Note that the pump starts to run in sync with the external signal as entering EXT mode.

NOTE

- Manual operation spm is applied as the EXT upper limit spm. For example, even if the external signal is entered to run the pump at 360spm, the pump does not run over 200spm as long as manual operation spm is 200spm
- A stroke rate skips from 360spm to 1spm by pushing the UP key once. Pay attention to this point when programming a stroke rate.

1 Enter manual mode.

Enter the manual mode to indicate spm on the screen.

- Push the start/stop key when "EXT" or ".0"- ".360" is on the screen.
- When "STOP" or "-STOP" appears on the screen, see "STOP function cancellation" on 60 page and release the STOPfunction.

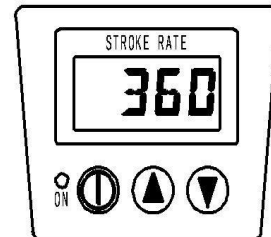

2**Use the UP or DOWN key to program the upper limit spm.**

Push the start/stop key and stop the pump when the pump is running. Then program spm.

- spm increases/decreases as pushing the UP/DOWN keys.
- Press and hold either key for more than three seconds for quick change. Quick change stops at 1 or 360spm. 1 or 360spm skips to 360 or 1 spm when the key is released and pushed again.

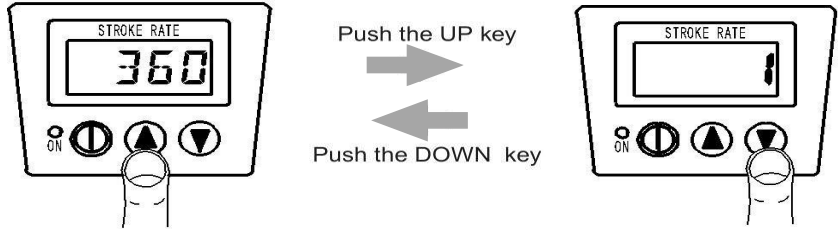
**3****Push the DOWN key while pressing the start/stop key to enter EXT mode.**

Note that the pump starts to run in sync with the external signal as entering EXT mode.

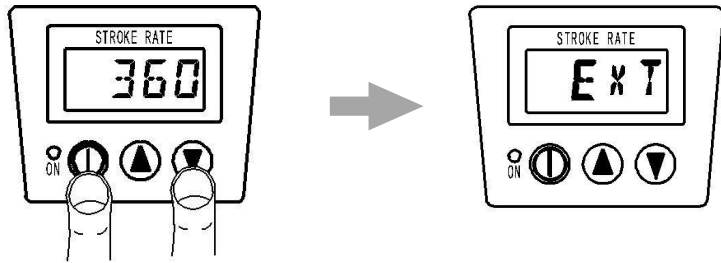
**EXT mode programming**

The following features can be programmed for the EXT operation.

- **Multiplier programming**

The number of shots per signal is programmed.

- **Divider programming**

The number of signals per shot is programmed.

- **Anti-chattering programming**

The read time of the pulse signal is programmed in consideration of the accrual of chattering in order to reduce noise.

- **Display selection**

Either "EXT" or "spm" indication is selected for EXT mode.

NOTE

Pushing the start/stop key, a program is entered. Do not forget to enter your programming. Note if the pump is unplugged before pushing the start/stop key, your programming is not stored.

Glossary

Chattering

A phenomenon the electrical signal repeats ON and OFF, disturbing pulse shape. The mechanical vibration which occurs when the relay or switch functions brings about this problem.

Multiplier programming

Program the number of shots per signal to control the pump. The number of shots can be programmed from 1 to 999.

NOTE

Do not enter the EXT signal during the programming.

1 Enter EXT mode.

- Push the DOWN key while pressing the start/stop key to move from manual mode to EXT mode.
- Push the start/stop key and stop the pump when the pump is running. Then call up EXT mode.

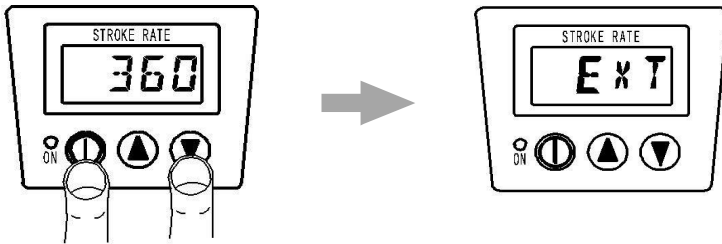

2 Push the UP key and enter the Multiply/Divide selection.

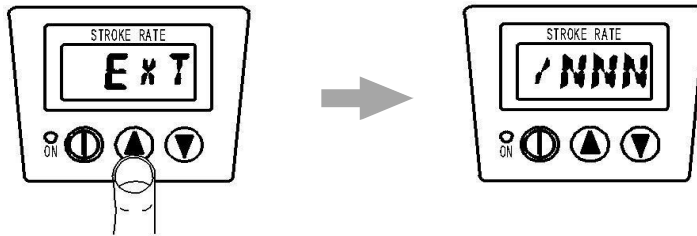

3 Select "X NNN" (Multiply).

"X NNN" (Multiply) or "/ NNN" (Divide) can be selected by the UP and DOWN keys.

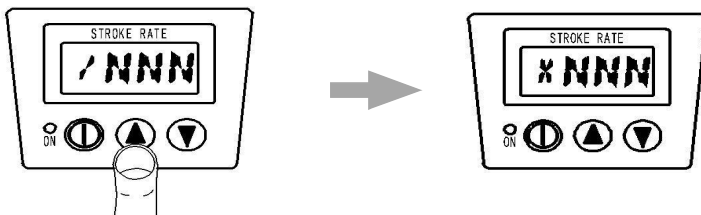

4 Push the start/stop key to return to EXT mode.

4

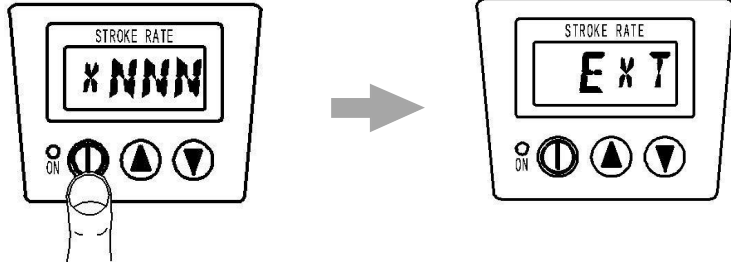

5 Push the DOWN key and call up the multiplier programming screen.

5

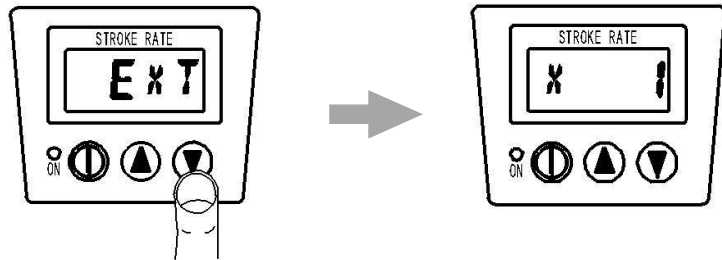

6 Use the UP or DOWN key to program a multiplier.

6

- A multiplier increases/decreases as pushing the UP/DOWN keys.
- Press and hold either key for more than three seconds for quick change. Quick change stops at 1 or 999. 1 or 999 skips to 999 or 1 when the key is released and pushed again.

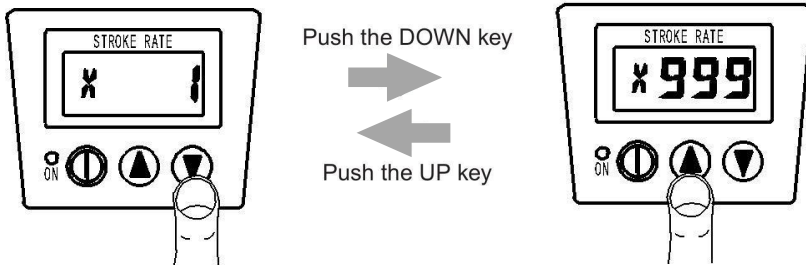

7 Push the start/stop key to return to EXT mode.

7

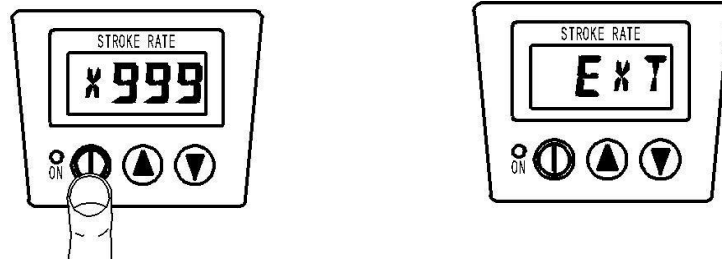

The pump runs according to the multiplier programming.

Divider programming

Program the number of signals per shot to control the pump. The number of signals can be programmed from 1 to 999.

NOTE

- If a divider is programmed to 1 to make 1:1 operation and the input interval of the external signal is close to a manual operation spm (but not exactly in synchronization), irregular operation may occur. This irregular operation occurs as the external signal is cancelled. Note that this is not malfunction. In order to avoid this phenomenon, perform 1:1 operation by programming a multiplier to 1.
- Do not enter the EXT signal during the programming.

Enter EXT mode.

- 1 • Push the DOWN key while pressing the start/stop key to move from manual mode to EXT mode.
• Push the start/stop key and stop the pump when the pump is running. Then call up EXT mode.

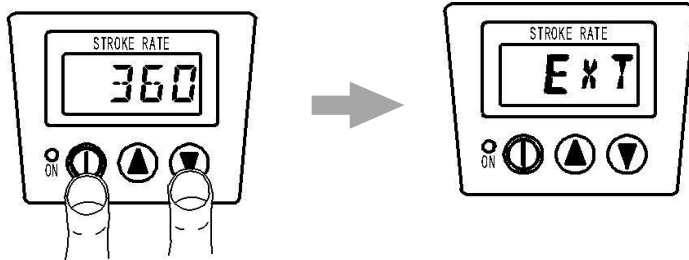

- 2 Push the UP key and enter the Multiply/Divide selection.

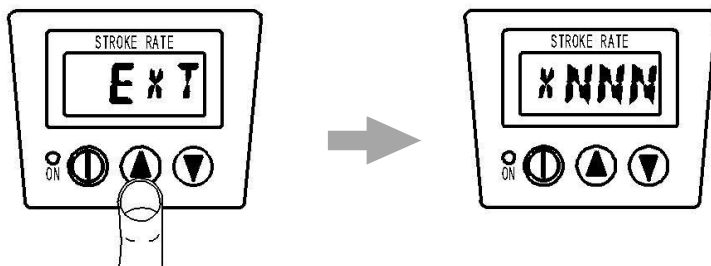

- 3 Select "/ NNN"(Divide).

"X NNN" (Multiply) or "/ NNN" (Divide) can be selected by the UP and DOWN keys.

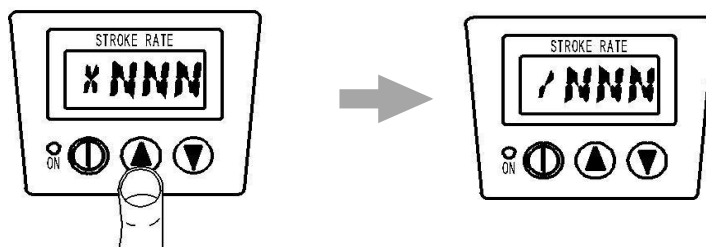

4 Push the start/stop key to return to EXT mode.

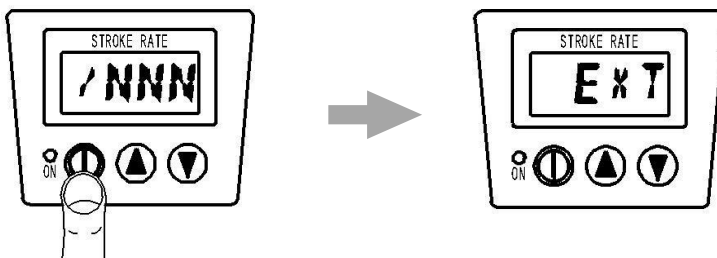

5 Push the DOWN key and call up the divider programming screen.

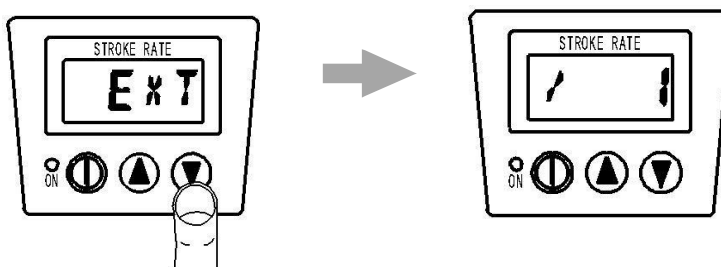

6 Use the UP or DOWN key to program a divider.

- A divider increases/decreases as pushing the UP/DOWN keys.
- Press and hold either key for more than three seconds for quick change. Quick change stops at 1 or 999. 1 or 999 skips to 999 or 1 when the key is released and pushed again.

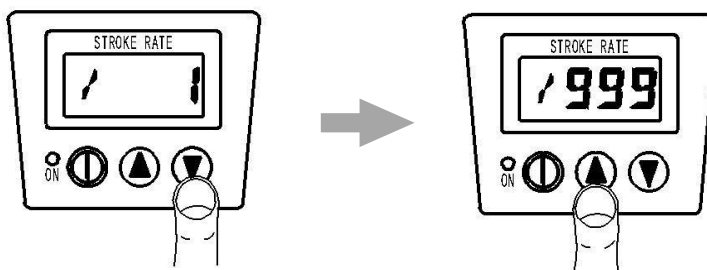

7 Push the start/stop key to return to EXT

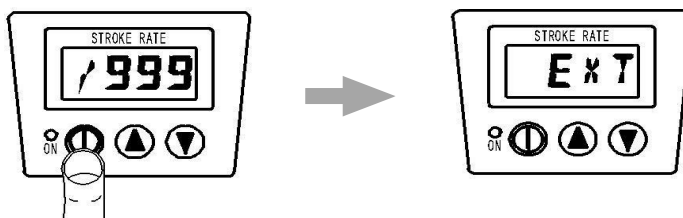

The pump runs according to the divider

Enter manual mode.

- 1 • Push the start/stop key to return to manual mode if the pump is in EXT mode.

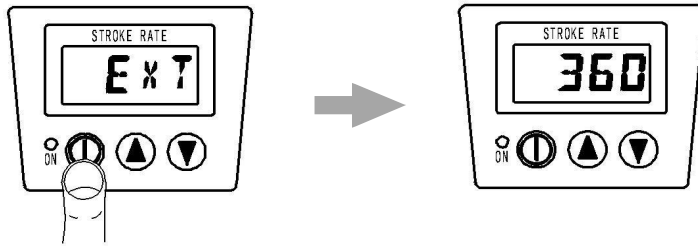

Push the UP key while pressing the start/stop key to call up the anti-chattering programming screen.

- 2 "T-5" (default setting), "T-10" or "T-50" appears on the screen.

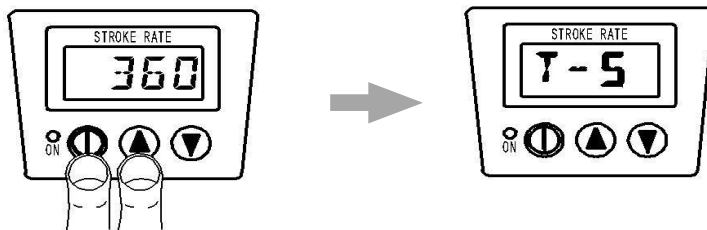

Push the UP key and select a read time.

- 3 Pushing the UP key cycles through "T-5", "T-10" and "T-50".
- * T-5, T-10 and T50 are the approximate time (msec) to read the external pulse signal.
 - * The controller becomes more resistant to chattering as read time is set longer but then becomes less capable of reading the short pulse signal. An ON time period of the pulse signal shall be longer than the read time.
 - * When this product is used in conjunction with the 50 series or the EUC-70P electromagnetic dosing pump controller, select "T-5" (defaultsetting).

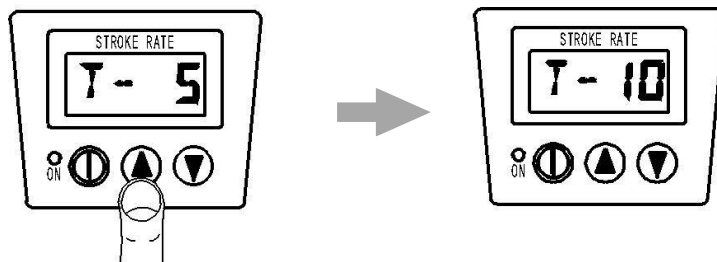

4 Push the start/stop key to return to manual mode.

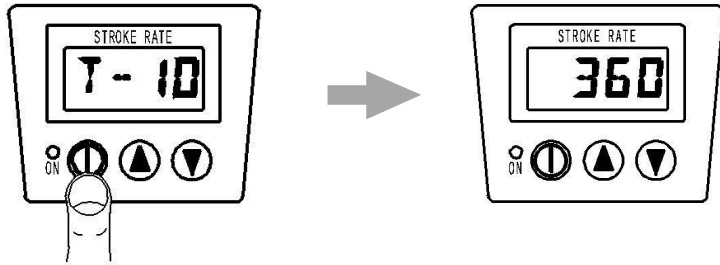

Display selection

Either "EXT" or "spm" indication is selected for EXT mode.

EXT indication appears when "EXT" is selected. A stroke rate appears when a spm indication is selected.

NOTE

- The spm indication shows a current stroke rate. The number of external pulse signals is not shown on the screen. Note that the stroke rate shown in EXT mode is an calculated spm and doesn't reflect a current spm exactly.
- Do not enter the EXT signal during the programming.

Enter EXT mode.

- 1**
- Push the DOWN key while pressing the start/stop key to move from manual mode to EXT mode.
 - Push the start/stop key and stop the pump when the pump is running. Then call up EXT mode.

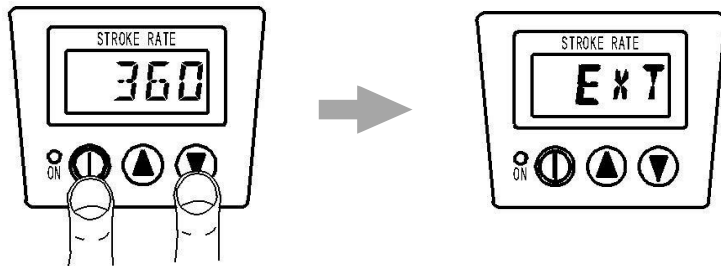

- 2 Push the DOWN key while pressing the UP key to call up the display selection screen.

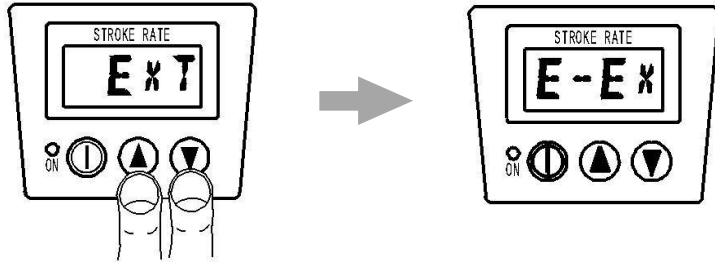

- 3 Push the UP or DOWN key to select "E-EX" (EXT indication) or "E-SP" (spm indication).

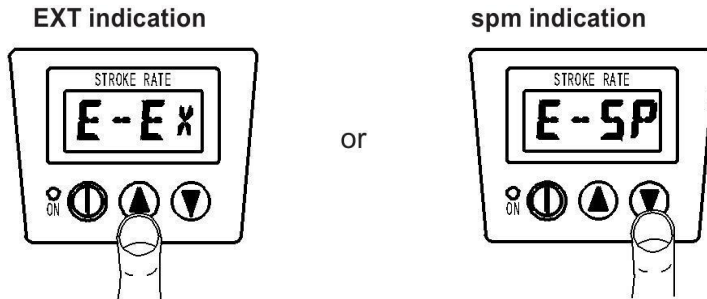

- 4 Push the start/stop key to return to EXT mode.

When spm indication is selected

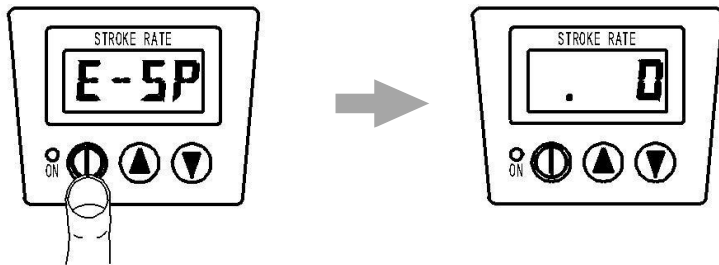

"EXT" appears on the screen when EXT indication is selected.

STOP function

The start/stop of the pump operation can be controlled by the external stop signal.

- **Operation stop at the stop signal input: "M-OFF"**
The pump stops while receiving the stop signal.
- **Operation starts at the stop signal input: "M-ON"**
The pump runs while receiving the stop signal. →

■ STOP function programming

Enter manual mode.

- 1 Push the start/stop key to return to manual mode if the pump is in EXT mode.

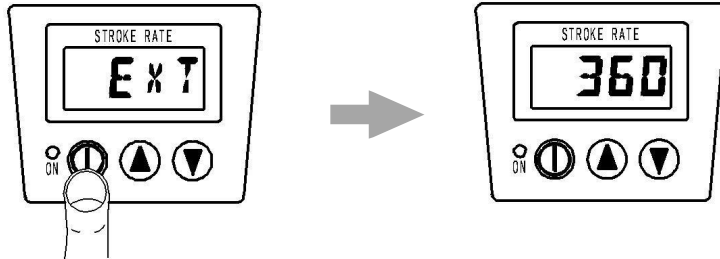

- 2 Push the UP key while pressing the start/stop key to call up the anti-chattering programming screen.

"T-5" (default setting), "T-10" or "T-50" appears on the screen.

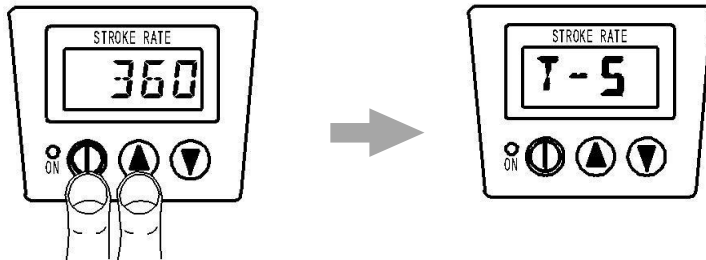

- 3 Push the DOWN key and call up the STOP function programming screen.

"M-OFF" (default setting) or "M-ON" appears on the screen.

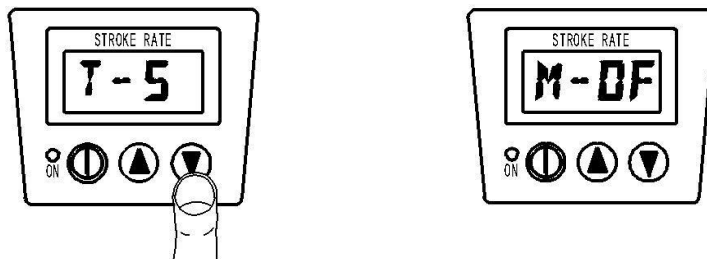

Push the UP key to select "M-OFF" (run during the signal input) or

4 "M-ON" (stop during the signal input).

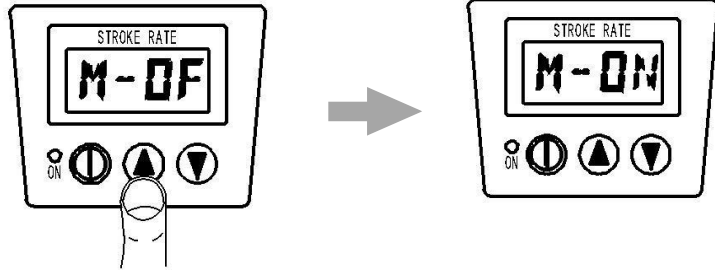

5 Push the start/stop key to return to manual mode.

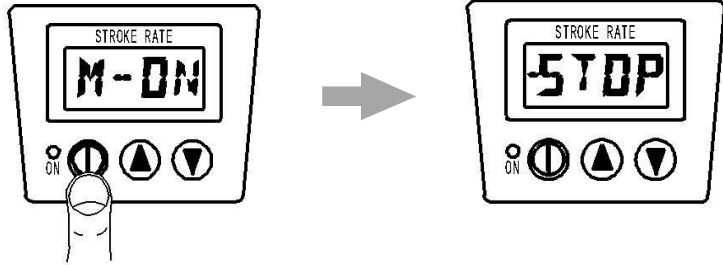

The screen indicates that the STOP function is active.

■ STOP function cancellation

A stop state can be cancelled if the current selection is changed.

Example) M-OF → M-ON

M-ON → M-OF

1 Enter the wait state in the manual mode with the STOP function active. "-STOP" appears on the screen.

- If the screen shows "STOP" or the pump is in the EXTmode, push the start/stop key to enter the "-STOP" state.
- Move to the next step if the pump is in the "-STOP" state.

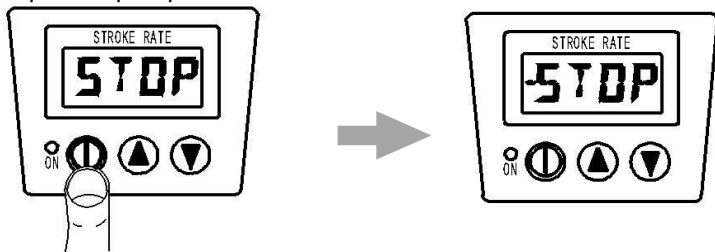

2 Push the UP key while pressing the start/stop key to call up the anti-chattering programming screen.

"T-5" (default setting), "T-10" or "T-50" appears on the screen.

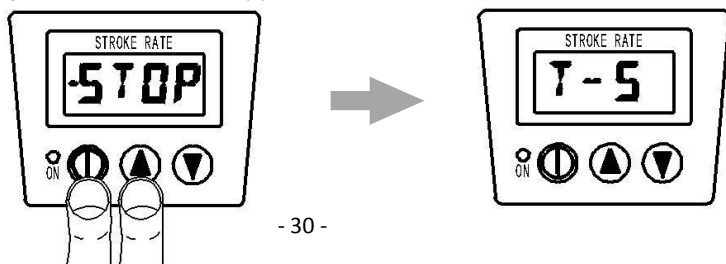

- 3** Push the DOWN key and call up the STOP function selection screen.

"M-OFF" (default setting) or "M-ON" appears on the screen.

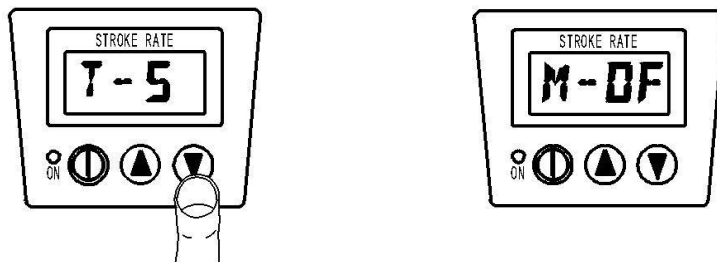

- 4** Push the UP key and change the current selection. If "M-OFF" is selected, change it to "M-ON". If "M-ON" is selected, change to "M-OFF".

When "M-OFF" is selected

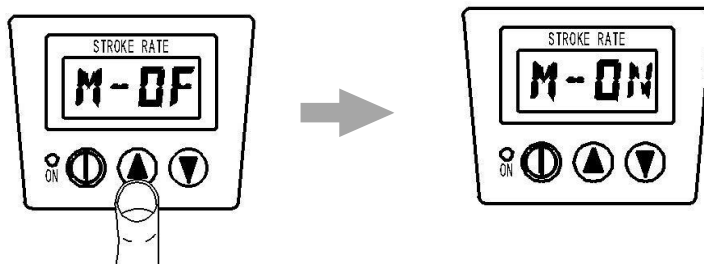

- 5** Push the start/stop key to return to the wait state in manual mode.

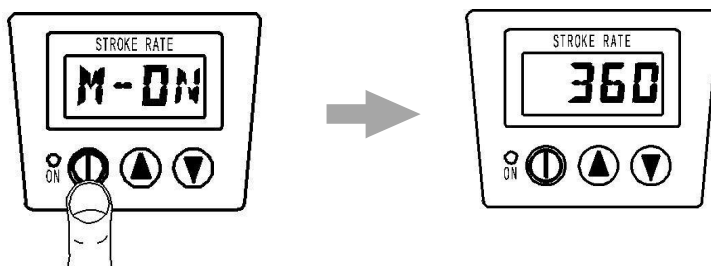

The STOP function now has been canceled.

Keypad lock

Keypad lock can be active in the following states for the prevention of erroneous key operation.

Manual mode

Wait state

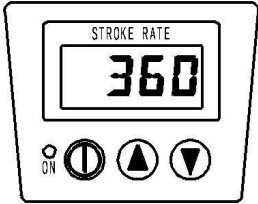

During operation

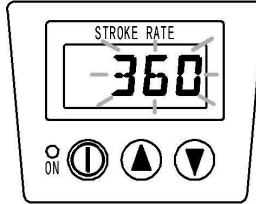

EXT mode

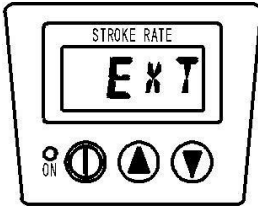

NOTE

- Any key operation is not acceptable when the keypad lock is active. In an emergency, unplug the pump to stop operation. In this case, keypad lock state is recalled when the pump is turned on.
 - Pressing the start/stop key for three seconds, keypad lock becomes active even when the pump is receiving the STOP signal. Note that "STOP" or "-STOP" indication does not change but key operation is not accepted. Keypad lock indication appears when the STOP signal is released with "M-ON" or inputted with "M-OFF".
-

■ Activate keypad lock

Push the start/stop key for more than three seconds.

■ Release the keypad lock state

Push the start/stop key for more than three seconds.

Keypad lock is released and key operation becomes acceptable.

States	Possible causes	Solutions
The pump does not run. (LED does not appear. Blank screen.)	Power voltage is too low.	<ul style="list-style-type: none"> Recover the power voltage to a normal level. Allowable voltage range: AC100-240V
	The pump is not powered.	<ul style="list-style-type: none"> Check the switch if it is installed. Correct wiring Replace a breaking wire to new one.
	An electronic circuit in the control unit is failed.	<ul style="list-style-type: none"> Replace the control unit.
Liquid can not be sucked up.	Air lock in the pump	<ul style="list-style-type: none"> Expel air.
	Stroke length is too short.	Run the pump at 100% stroke length and adjust it to proper length.
	Air ingress through suction line.	<ul style="list-style-type: none"> Correct tubing.
	A valve set is installed upside down	<ul style="list-style-type: none"> Reinstall the valve set.
	Valve gaskets are not installed.	<ul style="list-style-type: none"> Install valve gaskets.
	Foreign matters are stuck in the pump head valves.	<ul style="list-style-type: none"> Dismantle, inspect and clean the valve. Replace as necessary.
The flow rate fluctuates.	A ball valve is stuck on a valve seat	<ul style="list-style-type: none"> Dismantle, inspect and clean the valve. Replace as necessary.
	Air stays in the pump head.	<ul style="list-style-type: none"> Expel air.
	Overfeeding occurs.	Mount a check valve.
	Foreign matters are stuck in the pump head valves.	<ul style="list-style-type: none"> Dismantle, inspect and clean the valve. Replace as necessary.
	Diaphragm is broken.	<ul style="list-style-type: none"> Replace diaphragm.
	Pressure fluctuates at an injection point.	<ul style="list-style-type: none"> Review tubing layout to maintain a pressure constant at an injection point or change an injection point in a constant pressure.

Liquid leaks	Loose fit of the fitting or the air vent body.	<ul style="list-style-type: none"> Retighten them.
	Loose fit of the pump head.	Retighten the pump head.
	O rings or valve gaskets are not installed.	<ul style="list-style-type: none"> Install O rings and valve gaskets.
	Diaphragm is broken.	<ul style="list-style-type: none"> Replace the diaphragm.
	Excessive discharge pressure.	<ul style="list-style-type: none"> Check that a discharge line is not closed. Check if tubing is not clogged.

Inspection

Perform daily inspection and periodic inspection to keep pump performance and safety.

Daily inspection

Check the following points. Upon sensing abnormal condition, stop operation immediately and remove problems according to "Troubleshooting".

When wear parts come to the life limit, replace them by new ones. Contact us or your nearest dealer for detail.

No.	States	Points to be checked	How to check
1	Pumping	• If liquid is pumped.	Flow meter or visual inspection
		• If the suction and discharge pressure are normal.	Check specification.
		• If liquid is deteriorated, crystallized or settled?	Visual or audio inspection
2	Noise and vibration	• If abnormal noise or vibration occurs. They are signs of abnormal operation.	Visual or audio inspection
3	Air ingress from pump head joints and a suction line	• If leakage occurs. • If discharge liquid includes air bubbles, check lines for leakage and retighten as necessary.	Visual or audio inspection

Periodic inspection

Retighten the pump head mounting bolts diagonally according to the following torque.

* Mounting bolts may loosen in operation. How fast the bolts start to loosen is depending on operating conditions.

Tightening torque

Model identification code	Torque	Bolts
EH-B10/15/20,C15/20	2.16 N•m	M4 Hex. socket head bolt
EH-B30	2.55 N•m	M4 Hex. socket head bolt
EH-C30	2.55 N•m	M4 Hex. socket head bolt
EH-C35	2.55 N•m	M4 Hex. socket head bolt

*A hexagon wrench can be used for a torque wrench.

Diaphragm replacement

Necessary tools

- Adjustable wrench or spanner
- Hexagon wrench
- Torque wrench

NOTE

Pay attention not to lose diaphragm spacers. Always apply a proper number of diaphragm spacers. 0 or a few diaphragm spacers are inserted between the retainer and plunger for the adjustment of diaphragm location. Note that the number of diaphragm spacers varies with pump model. Some pumps may use no spacer.

Specification

Specifications and apparent condition are subject to change without notice.

■ Pump unit

Model code	Discharge amount ml/min	Discharge amount of each stroke ml/shot	Discharge pressure MPa	Stroke rate spm	Tube connection bore mm	Power consumption W
EH-B10	38	0.05~0.11	1.0	0~360	ø4×9	20
EH-B15	65	0.09~0.18	0.7			
EH-B20	95	0.13~0.26	0.4			
EH-B30	200	0.28~0.56	0.2		ø8×13	24
EH-C15	80	0.09~0.22	1.0			
EH-C20	130	0.14~0.36	0.7			
EH-C30	270	0.30~0.75	0.35			
EH-C35	400	0.44~1.11	0.2		ø8×13	

1. The performance of the pump is obtained by clean water under a rated voltage and ambient temperature.
2. The above parameters are measured with clean water. The discharge amount increases when discharge pressure decreases.
3. Allowable ambient temperature: 0~40° C
4. Allowable liquid temperature: 0~40° C
5. Allowable voltage deviation: ±10% of the rated voltage
 - 1) The allowable voltage range of special circumstances, such as the transmission of slurry, please consult us.
 - 2) Due to product improvement, the product specifications may change without prior notice.

■ Control unit

Operation mode	Mode	Manual
		EXT (Pulse multiply or divide)
	Switch	Key operation
Stroke rate	Setting range	0~360spm
	Setting method	UP or DOWN key
	Storage function memory function	Non-volatile memory
STOP function	M-OFF	The pump runs during contact input.
	M-ON	The pump stops during contact input.
	Input signal	No-voltage contact or open collector* ¹
EXT mode	Upper limit spm	Manual operation spm
	Pump control	n shots per signal (Multiply) n signals per shot (Divide) 1:1 operation with n=1
	Input signal	No-voltage contact or open collector
	Operating frequency programmable range	0~360spm
Indicator	Numeric indication	4-digit LCD
	Operation	Green LED (Blinks at each shot)
Power voltage		AC100-240V 50/60Hz* ²

*1 The maximum applied voltage to the contact is 12V at 5mA. When using a contact type relay, the minimum application load should be 5mA or below.

*2 Observe the specified power voltage range. Otherwise failure may result. The allowable voltage range is AC100-240V.

Outer dimensions

● EH-B10/15/20

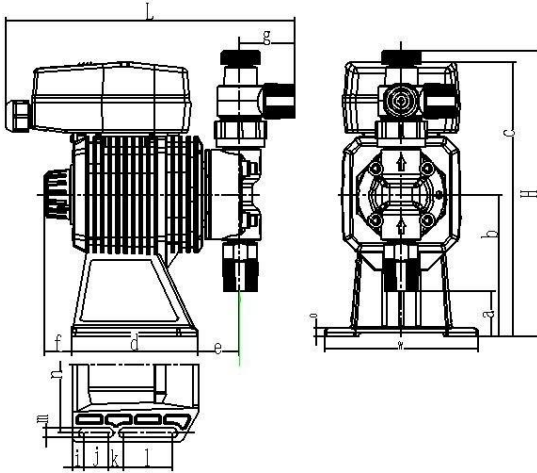

● EH-B30

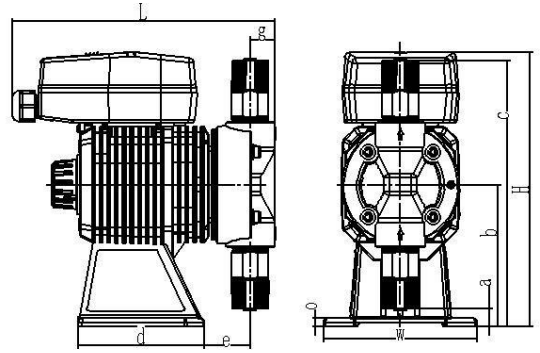

● EH-C15/20/30/35

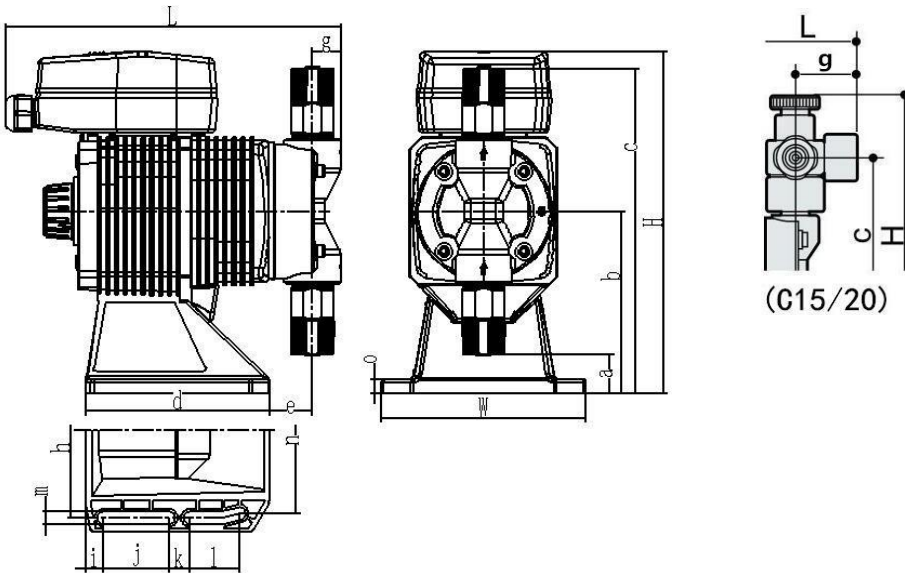

Model	W	H	L	a	b	c	d	e	f	g	h	i	j	k	l	m	n	o
EH-B10/15/20	100	185	186	29	92	153	82	28	18	36	88	7	16	10	32	6.2	88	5
EH-B30	100	178	172	11	92	173	82	30	18	16	88	7	16	10	32	6.2	88	5
EH-C15/20	116	196	207	40	103	164	104	22	24	36	100	10	37	12	28	7	95	8
EH-C30/35	116	194	190	22	103	184	104	24	24	16.5	100	10	37	8.5	27	7	95	8

SHANDONG LANGO METERING PUMP TECHNOLOGY CO., LTD

ADD: Building 2, No. 850 Government Street, Muping District, Yantai City, Shandong Province

WEBSITE: www.langopump.com

E-MAIL: sale@langopump.com

Ver.: EH-M-2024/A